

# *Student Experiments*

Manual

# FORCES AND TORQUE

P9160-1P



# INDEX

## 1. EQUILIBRIUM ON THE HORIZONTAL FORCE TABLE

- MEK 1.1            Composition of several forces
- MEK 1.2            Force direction and application point

## 2. EQUILIBRIUM ON THE HORIZONTAL FORCE TABLE

- MEK 2.0            Setup of the experiments
- MEK 2.1            Equilibrium of torques
- MEK 2.2            Force direction on a two-sided lever

## 3. COMPUTER- ASSISTED DATA LOGGING

- MEK 3.0            Setup of the electronic data acquisition
- MEK 3.1            Rotation - measuring of the moment of inertia
- MEK 3.2            Dependence on the moment of inertia of the mass distribution
- MEK 3.3            Rotation – moment of inertia

# FORCE DIRECTION AND APPLICATION POINT

MEK 1.2

## Required Kit:

P9901-4A Rail stand material

P9902-4P Forces and torque

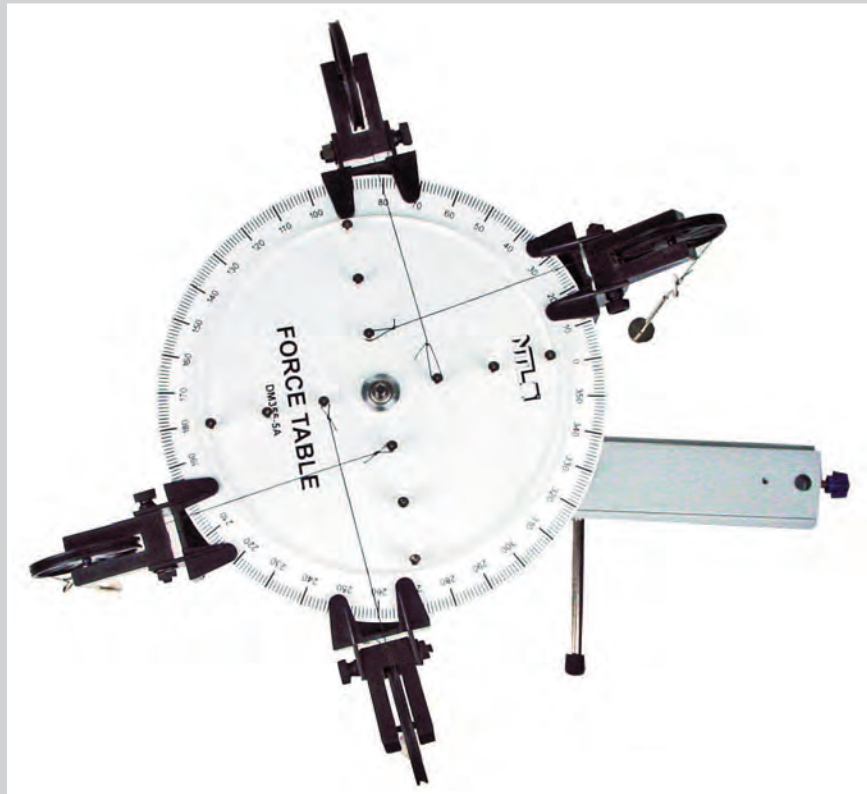

## Material:

- 1x Standrail, 300 mm
- 2x Rod 250 x 10 mm
- 2x End-cap for rods
- 1x Round bosshead
- 1x Force table
- 1x Torque accessory for force table
- 4x Threads with loops for torque accessory
- 4x Pulley with very low friction
- 4x Holder for slotted weights, 10 g
- 3x Slotted weight, 5 g
- 4x Slotted weight, 10 g
- 1x Slotted weight, 20 g
- 5x Slotted weight, 50 g

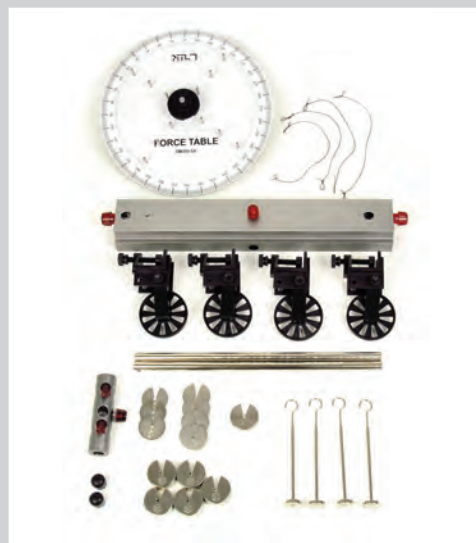

# FORCE DIRECTION AND APPLICATION POINT

## MEK 1.2

Basically, quantities in physics are either scalar or vector quantities. There are three important factors: force direction, magnitude of the force and the point where the force acts on a body. If the force acts at the centre of mass of a body, the body can only be translated in one direction. If the same force has another application point, for instance at the edge of a wheel, it depends on the force direction if the body is only translated or if it rotates. The body will generally start to rotate if the prolongation of the vector of the acting force does not touch the centre of mass (respectively the fulcrum).

The longer the door handle, the easier it is to push the door handle down. The longer the lever, the easier it is to lift something up with the lever. Conclusion: Not only the magnitude and the direction of the force are decisive, but also the application point. Hence, a force can put a body into rotation. The torque of the force determines whether the body is going to move and in what way. Torque  $\vec{N}$  is a vector. In three dimensions it can be calculated with this equation:

$$\vec{N} = \vec{F} \times \vec{r}$$

In this case,  $F$  is the acting force and  $r$  is the vector between the centre of rotation and the application point of the force. In three dimensions  $N$  is perpendicular to  $F$  and  $r$ . If  $F$  and  $r$  are normal to each other, the magnitude of  $\vec{N}$  will be the biggest.

In our two-dimensional experiments there are only two possible directions for the torque. It acts either clockwise or anticlockwise. By convention, a clockwise torque is negative. The magnitude of the torque can be calculated with:

$$|\vec{N}| = |\vec{F}| * |\vec{r}| * \sin \theta$$

$\theta$  is the angle between the vectors  $F$  and  $r$ .

The relation torque-rotation is equal to the relation force-translation (linear motion). Therefore, there is a law of inertia also for rotation:

**A body remains at rest if there is no acting torque. If the body is already rotating, the rotation will stay uniform.**

(That is also true if the torques acting on a body are completely balanced.)

Our next experiment deals with bodies that have torques in equilibrium.

# FORCE DIRECTION AND APPLICATION POINT

MEK 1.2

## Preparation:

Setup as shown in picture.

Push one of the support rods,  $L=250$  mm, through the cross hole of the stand rail and fix it with a knurled screw. Place the plastic caps at both ends of the support rod. Connect the second support rod,  $L=250$  mm, to the force table by using the round bosshead. Fix the other end of the support rod vertically in the stand rail. Screw the torque accessory to the force table. Attach the four cords to the four inner dowels of the torque accessory (distance to centre: 2.5 cm; distance between dowels: 2.5 cm respectively). Adjust to the other ends of all the cords a holder for slotted weights. Fix the four pulleys so that there is a  $90^\circ$  angle between the lever arm (tie line between centre and application point) and its corresponding force. Fix the cords in order to accomplish equilibrium of torque. That means: two torques of equal size act in both directions (see picture).



“Basic position”: torques are balanced.

# FORCE DIRECTION AND APPLICATION POINT

MEK 1.2

## Experiment 1:

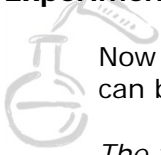

Now load one of the holder for slotted weights with an additional weight of 20 g. What can be noticed?

*The turntable starts to turn according to the acting torque.*

Which holders must be loaded with a total mass of 20 g to accomplish a state of torque equilibrium?

*The 20 g can be randomly split to the two holders that act in opposite direction.*

Which of the torques act in the same direction?

*The two opposite to each other, respectively.*

Remove the masses. Only the holders for slotted weights remain attached to the cords.

## Experiment 2:

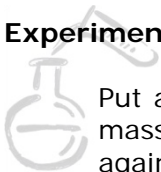

Put an additional weight of 50 g on the three holders for slotted weights. Increase the mass on one holder to a total mass of 120 g (holder 10 g + masses 110 g). We have again a disturbed equilibrium. To which retaining dowel must we attach one of the two counteracting cords to balance again the total torque? (before changing the cords it is important to position the pulleys in a way that the cord passes straight over the pulley. Check also the angle between the lever arm and the force. It must be again  $90^\circ$  because also the sine of this angle is decisive for the magnitude.

*One of the two counteracting cords should be attached to the retaining dowel that can be found 2.5 cm further outside.*

Is it possible to balance the torque by doubling two forces acting in the same direction without doubling also the counterforce? How?

*You could attach both counteracting cords to the correspondent retaining dowels that are 5 cm away from the centre.*

# FORCE DIRECTION AND APPLICATION POINT

## Experiment 3:

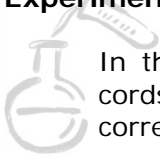

In this experiment three of the four torques act in the same direction. Attach three cords to the retaining dowels that are 5 cm away from the centre. Place the corresponding pulleys in the right position (see picture on the next page).

Only the holders for slotted weights and an additional weight of 5 g respectively are attached to the three cords. The fourth force must act on one of the four inner retaining dowels. This fourth torque is to balance the other three. What mass must be attached to the cord?

*Attach a total mass of 90 g to the fourth cord so that the torque is balanced.*

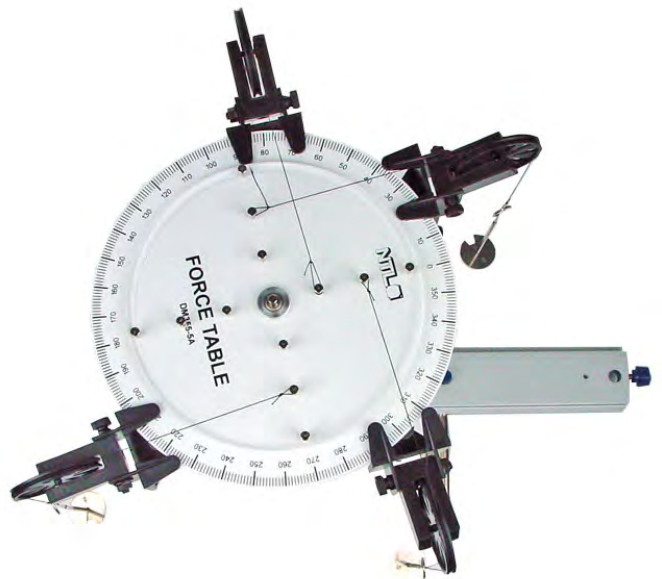

# FORCE DIRECTION AND APPLICATION POINT

MEK 1.2

## Experiment 4:

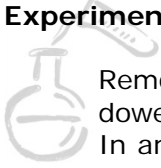

Remove one of the pulleys. Put three of the four cords around three inner retaining dowels (we do not need the fourth cord). Attach a weight of 0.6 N to one of the cords. In an angle of  $90^\circ$  attach a weight of 0.6 N. Attach a weight of 0.6 N also to the other two cords. What angle of lever arm and force is necessary to balance the torque (the angles must be equal; if they are not, there will be an infinite number of different solutions)? Find the solutions and set the result on the force table by using a set square. In that way you can test the equilibrium.

*The angles must be  $30^\circ$  or  $150^\circ$  and  $210^\circ$  or  $330^\circ$ , respectively. The sine of the first two angles is 0.5, the sine of the second angles is -0.5.*



### Conclusion:

A torque in consequence of a force depends on the distance between the line of application of the force and the centre of rotation. (= lever arm)

If the distance between application point and centre of rotation =  $r$ , and if the angle between force direction and tie line application point – centre of rotation =  $\alpha$ , the lever arm =  $r \cdot \sin \alpha$ .

The longer the lever arm, the bigger the torque (given a constant force).

Law of inertia for rotation: A body remains in uniform rotation (constant angular velocity) or at rest or if there is no acting torque.

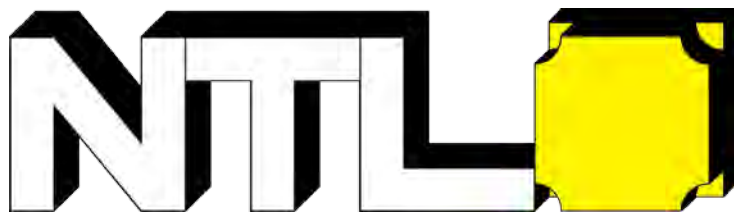

# *Student Experiments*

© Fruhmann GmbH  
NTL Manufacturer & Wholesaler

Werner von Siemensstraße 1  
A - 7343 Neutal  
Austria

[www.ntl.at](http://www.ntl.at)